



DIRECTIONAL LEDS



3730 SERIES

SAE Class II Surface Mount

This compact and versatile surface-mount LED directional light is ideal for applications requiring high intensity output, low current draw and maintenance-free operation. Premium LED heads feature a clear acrylic lens optic with LEDs that illuminate in the color of your choice. Warning capability can be customized by selecting from 14 flash patterns (via a trigger wire) and synchronizing multiple heads simultaneously or alternately. The coated aluminum base and urethane-sealed electronics protect the unit against the environment, making this one of the most rugged LED products available. And, it's covered by a full 5-year warranty.

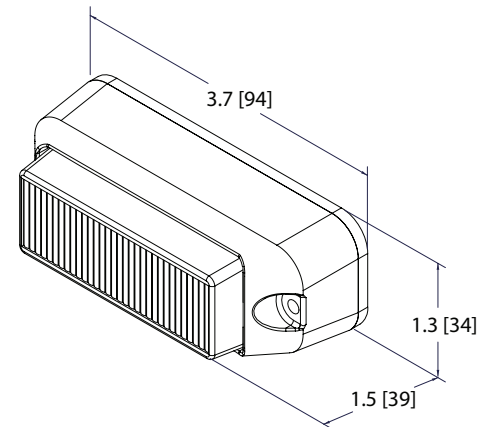

Models

PART NO.	VOLTAGE	AMPS	MOUNT
3730X	12-24	0.5	Surface

Replace X in part number with desired LED color: A = amber, B = blue, C = clear, R = red

Features and Benefits

- Rugged die-cast coated aluminum housing with urethane-encapsulated electronics
- 14 flash patterns, including three integral alternating flash modes
- Discrete units are colorless when not illuminated
- Multiple units can be synchronized
- Temperature Range: -22°F to +122°F (-30°C to +50°C)

Flash Patterns (14)

- Steady Burn
- Single
- Fast Single
- Double
- Triple
- Quad
- Quint Hold
- Fast Double
- Constant Pulse8
- Pulse8
- Double Alternate
- Quad Alternate
- Quint Hold Alternate
- Random

Accessories

UNIVERSAL
A3730BKT



TRUNK
A3730TNK



DECK
A3730DCK



WINDOW
A3730WIN



LICENSE
A3730LIC

